

Receiver

SETUP

INSTRUCTIONS

HELPFUL TIPS

- If you are not seeing the screens listed in this guide, try changing your TV's input by pressing the "Source/Input" button on your TV.
- When you reach the activation stage of this guide, you will need either your account number or your previous receiver's ID number.
 - Account number: Located along the upper-right corner of your DISH bill or in the My Account Summary section of your mydish.com account.
 - Receiver ID: Located on a label on the back of your previous receiver. It begins with "R."
- In step 7, your replacement receiver will test your Internet and phone connection. If the results display as "not available," ensure the cords are connected to the appropriate ports on the back of your receiver and to your phone/modem.
- To find your closest UPS dropoff location or to schedule a pickup at your cost, call 1-800-742-5877 or visit [ups.com/dropoff](https://www.ups.com/dropoff).

Do you have questions?

Take a look at the back cover of this guide to contact DISH!

01

Disconnect Your Cables and Remote Antenna

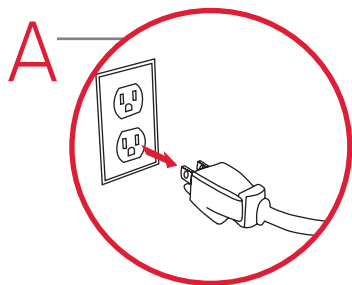

Locate the power cable for the receiver that you are replacing, and unplug it from the wall.

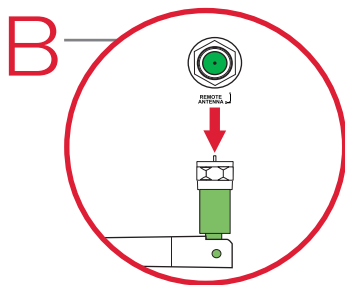

Locate the antenna connected to the “Remote Antenna” port. Then unscrew the antenna from the receiver.

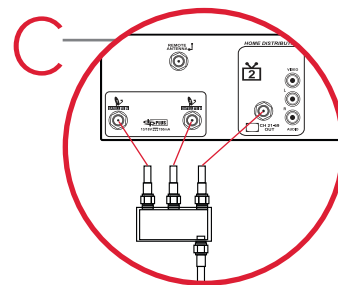

Locate the cables connected to the “Satellite In” ports and the “Home Distribution” port, and then unscrew them from the receiver. Do not unscrew the cables from the wall.

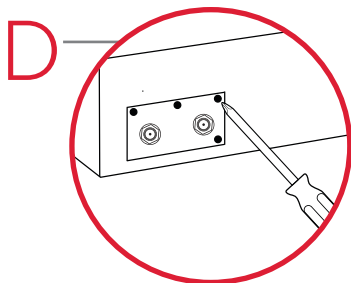

If applicable, unscrew the over-the-air (OTA) Module; set it aside. **(You may not have this accessory.)**

01

Disconnect Your Cables and Remote Antenna

E Determine the cable you are using to receive audio/visual signal. Then unplug it from the receiver, but not from your TV.

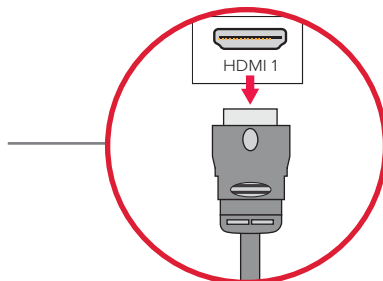

HDMI CABLE

OR

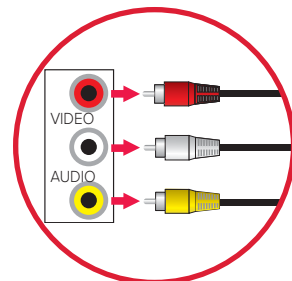

RCA CABLES

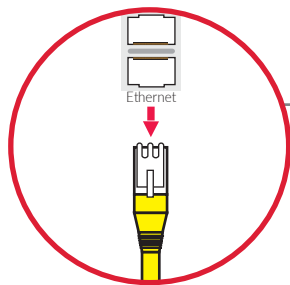

F Locate the cable connected to the “Ethernet” port. Then, unplug the cable from the receiver. Do not unplug it from the wall. **(You may not have this cable.)**

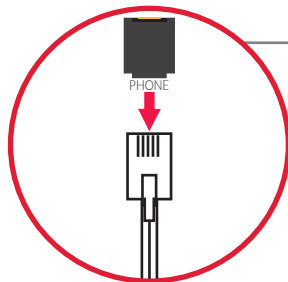

G Locate the cable connected to the “Phone” port. Then unplug the cable from the receiver. Do not unplug it from the wall. **(You may not have this cable.)**

02 Connect Your Cables and Remote Antenna

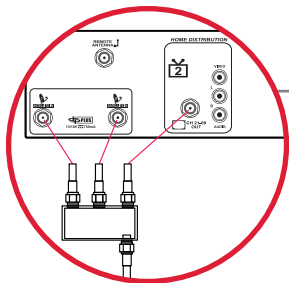

A Connect the Satellite In cables to the “Satellite In” ports and the Home Distribution cable to the “Home Distribution” port on your replacement receiver.

B Connect the remote antenna to the “Remote Antenna” port on your replacement receiver.

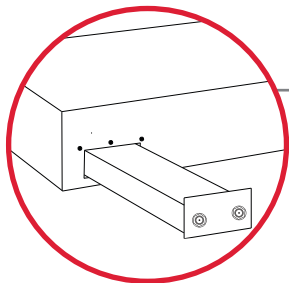
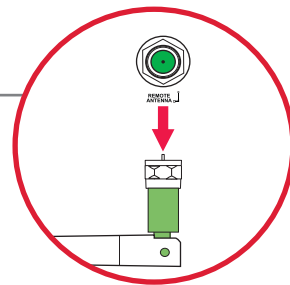

C If applicable, unscrew the cover on the back-left side of your replacement receiver. Slide in the OTA module, and then secure it by reattaching the screws. **(You may not have this accessory.)**

02 Connect Your Cables and Remote Antenna

D Connect either the RCA cables or the HDMI cable to the corresponding port(s) on your replacement receiver.

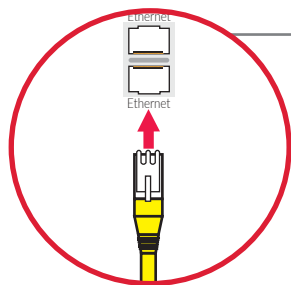
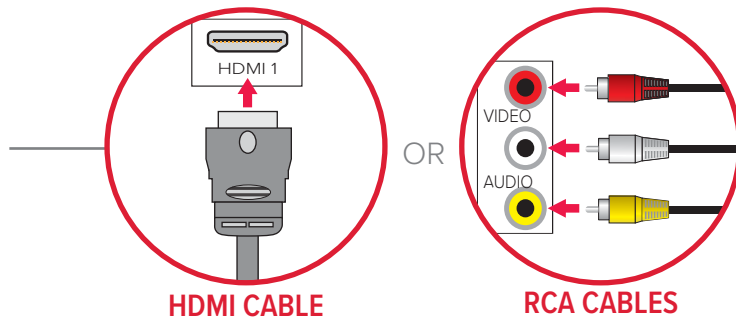

E Connect the Ethernet cable to the “Ethernet” port on your replacement receiver. **(You may not have this cable.)**

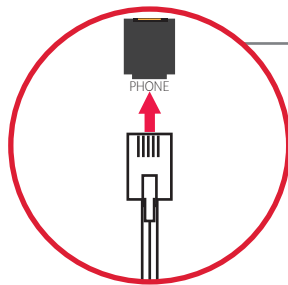

F Connect the Phone cable to the “Phone” port on your replacement receiver. **(You may not have this cable.)**

03

Power Your Equipment

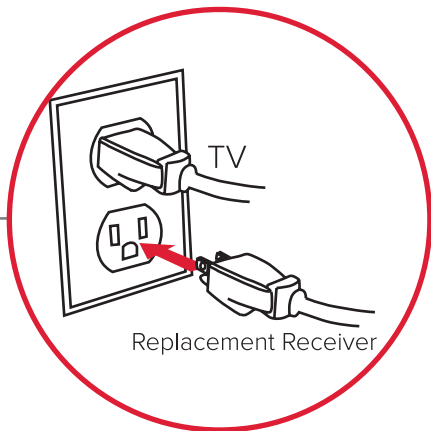

A Plug the power cord from your receiver into a power outlet, and ensure that your TV is still plugged in. Turn on your TV. It could take up to 30 seconds for you to see any images.

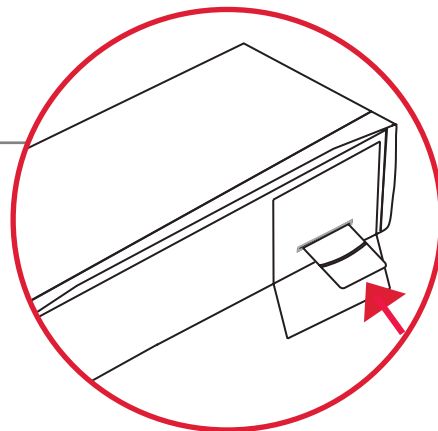

B Make sure that the SmartCard is secured firmly in the slot on the front of your receiver.

04

Program Your Remote

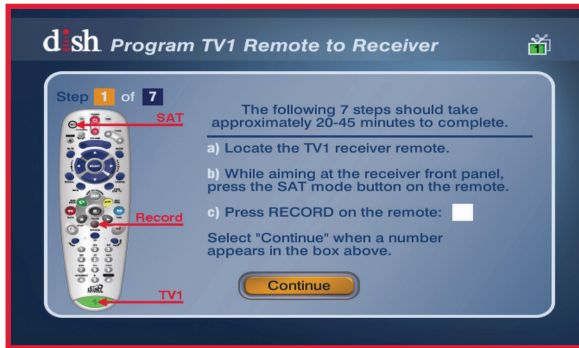

A Your screen should now display the Program TV1 Remote to Receiver screen. Follow the onscreen instructions to program your remote that has a green number 1 identifier at the bottom to the replacement receiver. Once your remote is programmed, use the arrow buttons on your remote to highlight "Continue," and then press Select.

B If you are using a second TV with this receiver, repeat to program the remote that has the blue number 2 identifier at the bottom. Once complete, use the arrow buttons on your remote to highlight "Continue," and then press Select.

05

Download Receiver Software

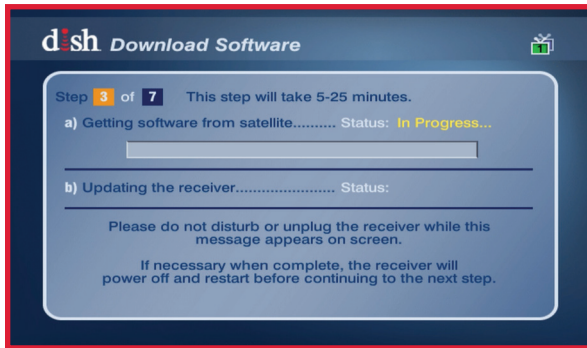

A Your receiver will start downloading software automatically.

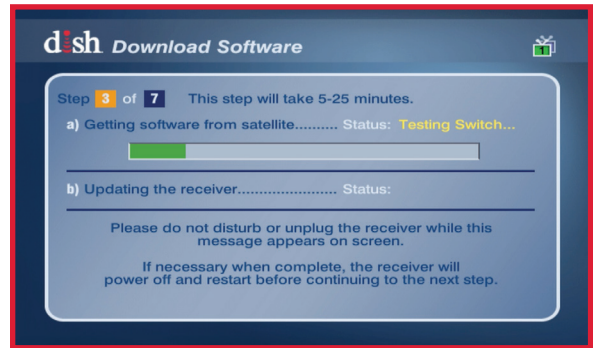

B Once the software download is complete, your receiver will update automatically.

06

Set Your TV Configuration

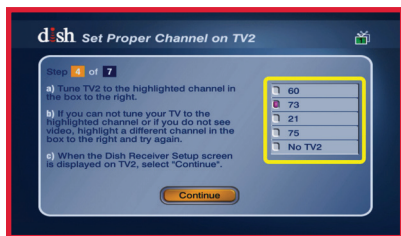

A If you have a second TV, see what channel it is currently tuned to by using the TV's remote or the buttons on the TV itself to channel up and then channel back down. Select the appropriate channel onscreen according to what channel your TV is tuned to, and then select "Continue."



B Follow the onscreen instructions to set your TV's video resolution so the picture will display properly.



C Once your TV resolution is set, use the arrow buttons on your remote to select "Save," and then press Select.

07

Test Your Internet & Phone Connection

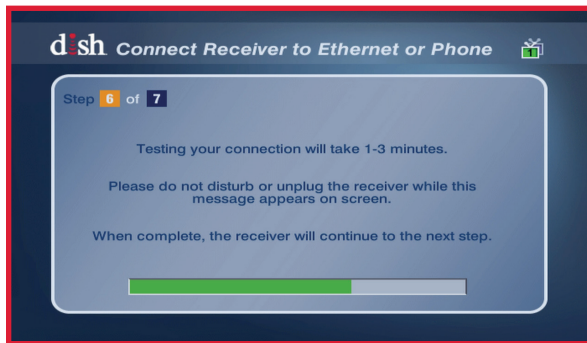

A Your receiver will automatically test your Internet and phone connection.



B Once complete, your receiver will display your connection status. Use the arrow buttons on your remote to highlight "Continue," and then press Select.

08

Activate Your Receiver

dish Activate Receiver

Step 6 of 7

Replacement receiver to be activated:

Receiver #: R1901346721 Smart Card #: 52330809468

Receiver to be replaced:

Receiver #: or Account #:

and Zip Code:

Continue

A If your receiver is connected to the Internet, enter your previous receiver's ID number. Or enter your account number and ZIP Code. Select "Continue."

dish Activate Receiver

Step 6 of 7

Please call 1-800-333-3474 to activate your receiver.

Receiver #: R1901346721-32
Smart Card #: 52330809468-90

B If your receiver is not connected to the Internet, please call 1-800-333-DISH (3474) to activate it. Note that you will need to provide the receiver and SmartCard numbers onscreen to the DISH agent.

dish Activate Receiver

Step 7 of 7

This step will take 10-15 minutes.

Please do not disturb or unplug the receiver while this message appears on screen.

When complete, the receiver will continue to the next step.

C Your receiver will go through the activation process, which can take up to 15 minutes.

09

Acquire Satellite Signal



A Use the arrow buttons on your remote to highlight “Live TV,” and then press Select.

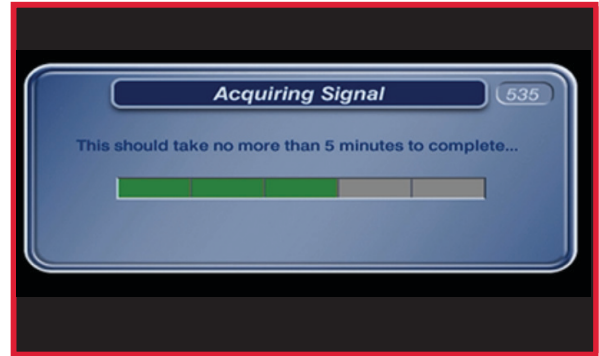

B Your receiver will automatically acquire satellite signal.

10

Download Program Guide

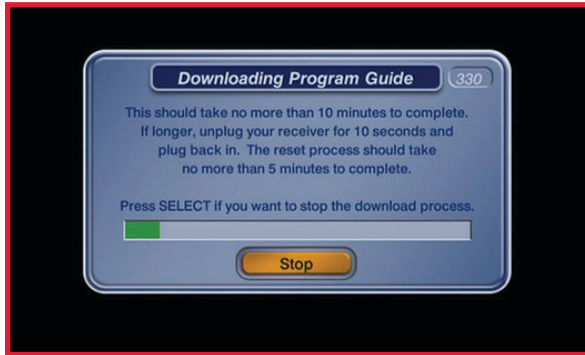

A Your receiver will automatically download the program guide.



B Once complete, your screen will display live TV.

11

Recycle Your Original Receiver

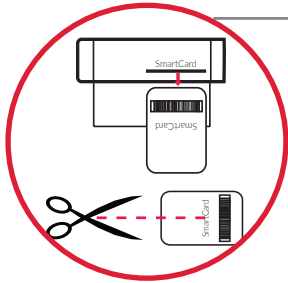

A Open the front panel on your original receiver and take out the SmartCard. Then cut the SmartCard lengthwise through the main chip.



B Visit mydish.com/recycle to find an e-waste recycling facility near you. Take your receiver to that facility.

Have questions?

Let us help!



Get product support information at mydish.com/support.



Find helpful instructional videos at youtube.com/user/dish.



Chat with a human being by visiting us at mydish.com/chat.

- OR -



Call us at 1-800-333-DISH (3474).

We want to hear from you

so that we can keep delivering what you need to enjoy your TV service.



Share your thoughts at mydish.com/tunedintoyou.